

DRIVER SIDE

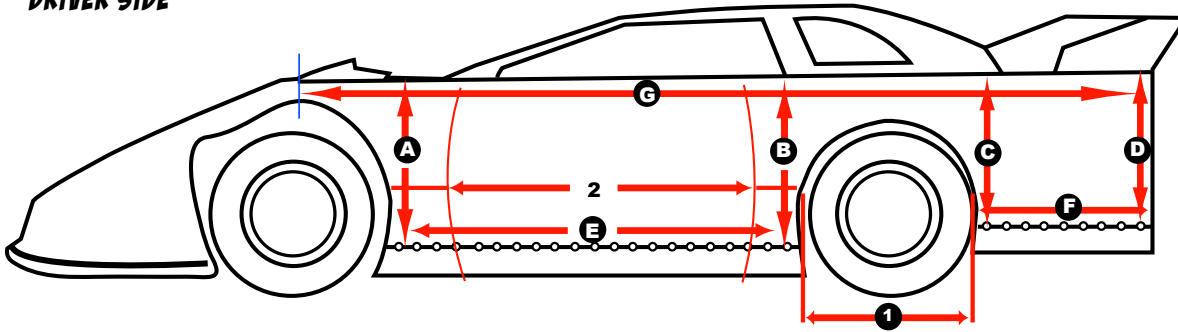

NOTE: DO NOT INCLUDE THE PLASTIC IN YOUR MEASUREMENTS.

- A: _____ INCHES (FRONT PART OF DOOR)
- B: _____ INCHES (BACK PART OF DOOR)
- C: _____ INCHES (FRONT PART OF FENDER)
- D: _____ INCHES (BACK PART OF FENDER)
- E: _____ INCHES (BOTTOM OF DOOR)
- F: _____ INCHES (BOTTOM OF FENDER)
- G: _____ INCHES (TOP OF DOOR/FENDER)
- BACK WHEEL WELL 1: _____

PASSENGER SIDE

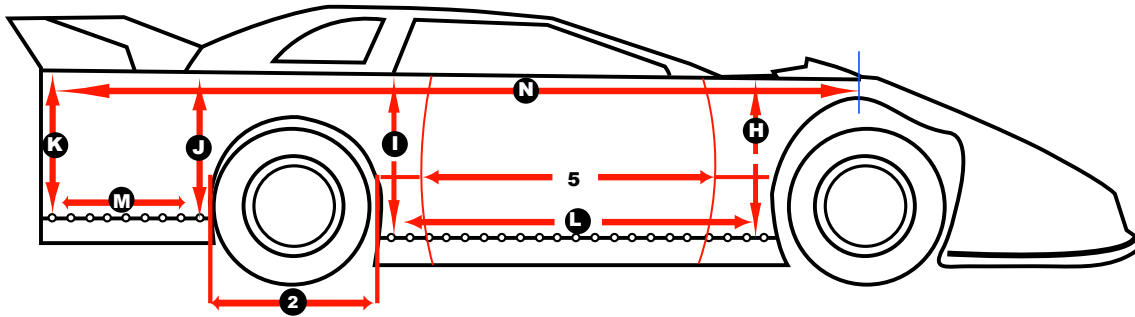

NOTE: DO NOT INCLUDE THE PLASTIC IN YOUR MEASUREMENTS.

- H: _____ INCHES (FRONT PART OF DOOR)
- I: _____ INCHES (BACK PART OF DOOR)
- J: _____ INCHES (FRONT PART OF FENDER)
- K: _____ INCHES (BACK PART OF FENDER)
- L: _____ INCHES (BOTTOM OF DOOR)
- M: _____ INCHES (BOTTOM OF FENDER)
- N: _____ INCHES (TOP OF DOOR/FENDER)
- BACK WHEEL WELL 2: _____

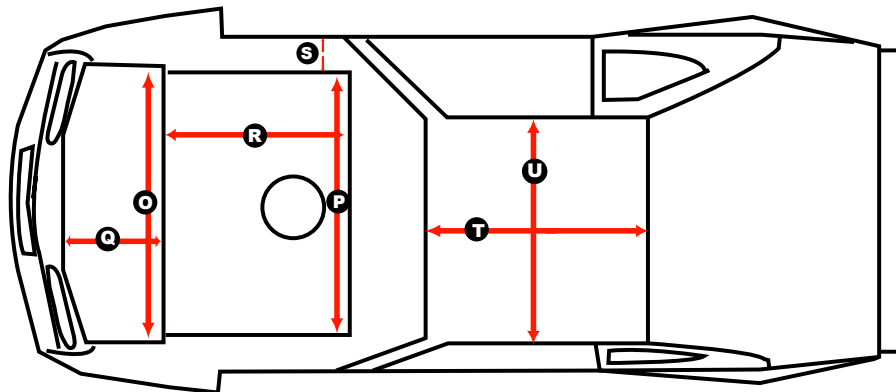

NOTE: DO NOT INCLUDE THE PLASTIC IN YOUR MEASUREMENTS.

- O: _____ INCHES
- P: _____ INCHES
- Q: _____ INCHES
- R: _____ INCHES
- S: _____ INCHES
- T: _____ INCHES
- U: _____ INCHES

BODY MANUFACTURER: _____